

PMC-L

large projector enclosure for PM-1 & PM-3

Product Features:

- 24"L x 20"D x 13"H inner dimensions
- lift off lid for installation & easy access hinge for maintenance
- adjustable front security bars for lens placement
- tamper proof security screws included
- black powder coat finish

Product Specifications: (for Architects & Engineers)

The projector enclosure for LCD projectors shall be the Video Mount Products (VMP) model PMC-L. The projector enclosure shall be primarily constructed of formed steel and shall incorporate arc welds. The enclosure shall be designed to work with the VMP projectors mounts PM-1 and PM-3. All hardware included with the PMC-S shall be security hardware and the front security bars shall be moveable to accommodate the lens position. The bottom of the enclosure shall be removable from the top for installation while still having the capability to remain hinged if desired for simple maintenance.

The dimensions of the enclosure shall be 24"L x 20"D x 13"H.

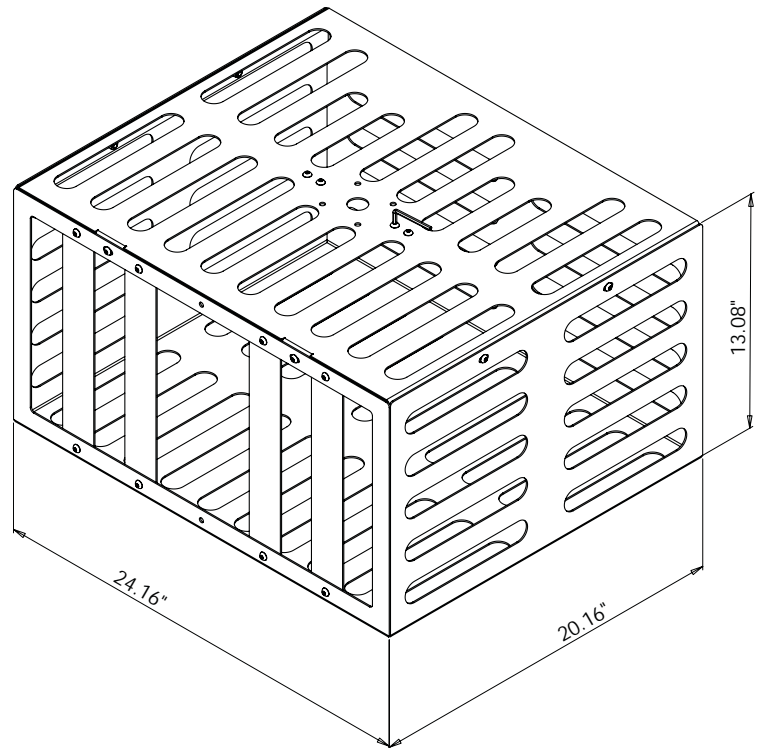

Video Mount Products
325 Log Canoe Circle
Stevensville, MD 21666
Phone: 410.643.6390
Fax: 410.643.6615
www.videomount.com

